

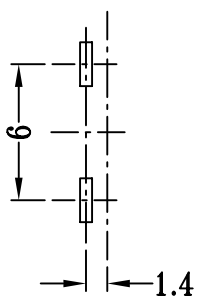

CAD FILE:

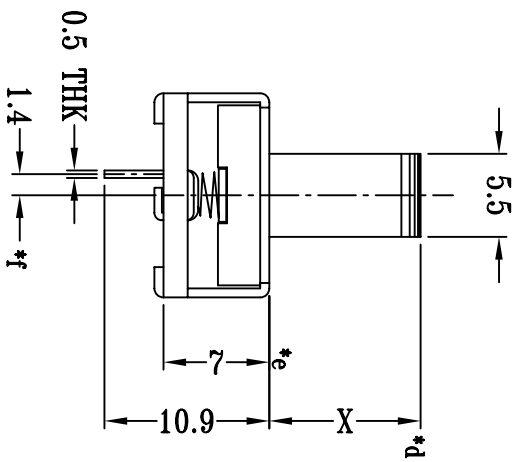

P.C.B LAYOUT

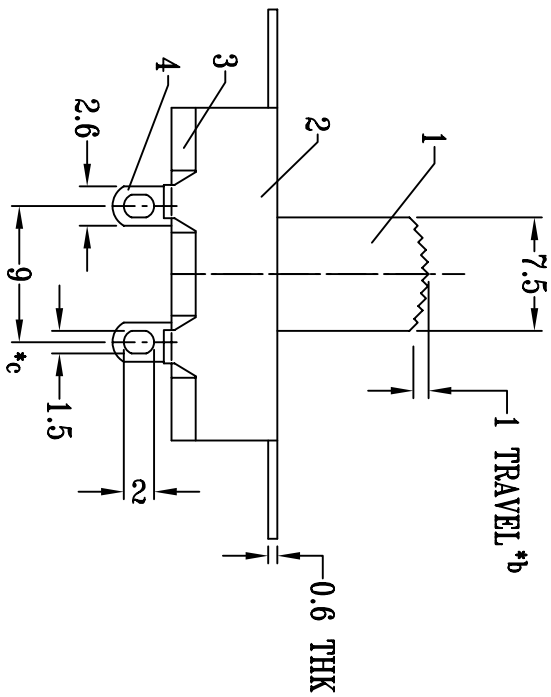
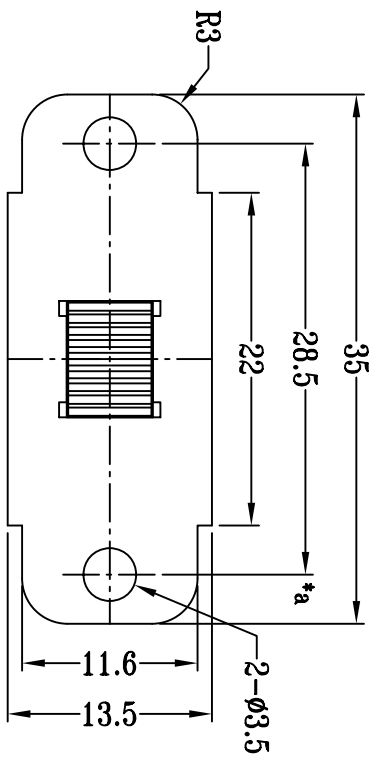
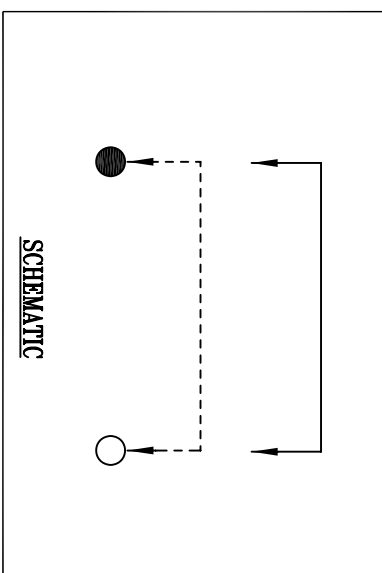

SCHEMATIC

8																				
7																				
6	SPRING	STEEL WIRE	1	TEMPER	TOLERANCE UNLESS SPECIFIED		SHENZHEN XIEJIA ELECTRONICS CO.,LTD.													
5	CONTACT	COPPER STRIP	1	Ag PLATED	WITHIN : 1.5±0.1mm	ISSUE	DATE	DESCRIPTIONS OF REVISION	APPD.											
4	TERMINAL	COPPER STRIP	2	Ag PLATED OVER Ni PLATED	OVER : 1.5±0.2mm	TITLE : PUSH SWITCH		UNIT : mm	SCALE: 2 : 1											
3	BASE	PHENOLIC RESIN	1	NATURAL	MODEL: PS-11A03		DRWG NO.: XJ-DR-PS11A03-00		DWN. ZHOUYU											
2	FRAME	STEEL STRIP	1	Zn PLATED	ALL MATERIALS MUST BE COMPLIANT TO ROHS		APPD. KANGXINAN		CHK'D FANGYING											
1	KNOB	NYLON+F.G+94V0	1	BLACK					APPD. KANGXINAN											
NO.	PARTS	MATERIALS	Q'TY	FINISH																

注:带*表示关键尺寸(6个)